

# SELF-VENTING (POLYPROPYLENE) - VDPX

APPROX WEIGHT: 2.15 lbs.  
DOES NOT INCLUDE WEIGHT OF POWER OR PACKAGING!!!

\*\*\* ANY ADDITIONS, DELETIONS, OR OMISSIONS MUST BE CORRECTED ON THIS DRAWING AS THIS DRAWING WILL BE CONSIDERED ALL INCLUSIVE \*\*\*  
ALL GRAPHICS PROVIDED ARE FOR REFERENCE ONLY. IF CERTAIN DIMENSIONS ARE CRITICAL PLEASE VERIFY THOSE DIMENSIONS WITH YOUR SALESPERSON

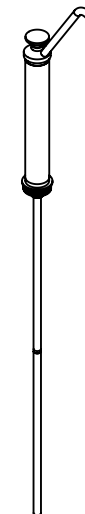
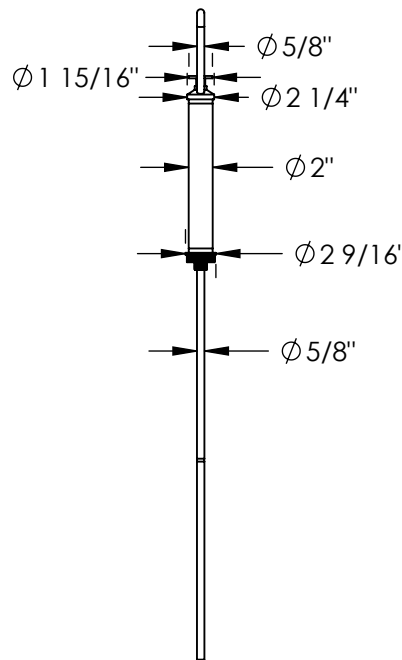
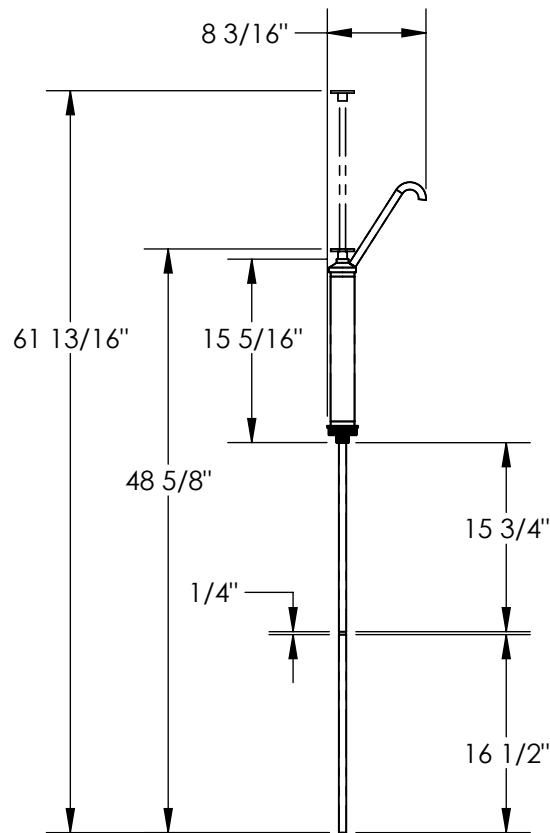

## STANDARD FEATURES

MODEL NUMBER IS VDPX  
OVERALL WIDTH IS 2 9/16"  
OVERALL LENGTH IS 8 3/16"  
OVERALL HEIGHT IS 61 13/16"  
DISPLACEMENT PER STROKE 16oz.  
FITS 3/4" & 2" BUNG  
CONSTRUCTION POLYPROPYLENE  
COMES WITH PAIL ADAPTER, CLAMPS, AND SLEEVES TO ADJUST DISPLACEMENT PER STROKE  
EXCEPTIONAL RESISTANCE TO CORRSIVE CHEMICALS (NON-FLAMMABLE SOLVENTS)

## SPECIAL FEATURES

NONE

DIMENSION TOLERANCE  $\pm 1/4''$

APPROVAL

I, THE UNDERSIGNED, AGREE THAT THE PRODUCT AS REPRESENTED SATISFIES DESIGN AND DIMENSION REQUIREMENTS. I ALSO ACKNOWLEDGE MY DUTY TO CONFIRM PRODUCT AND INSTALLATION COMPLIANCE WITH ALL APPLICABLE FEDERAL, STATE AND LOCAL REGULATIONS AND STANDARDS.  
**ALL SPECIAL UNITS ARE NON-RETURNABLE**  
[ ] As drawn [ ] As marked

Signed: \_\_\_\_\_ Date: \_\_\_\_\_

LEAD TIME WILL START UPON RECEIPT OF SIGNED APPROVAL DRAWING

DISTRIBUTOR'S NAME:		P.O.#
VESTIL MANUFACTURING		X
DRAWN BY: RS		DATE: 08/22/2012
REFERENCE: X		SCALE: 1:16
QUOTED LEAD TIME: X	QUOTE #	FILE NAME:
X	X	40-007-057